



深圳市凯琦佳科技有限公司

Catchy and Excellent Capacitor Technologies Co., Ltd.

深圳市凯琦佳科技有限公司

铝电解电容器

FE20600332M5C590 600V3300uF $\Phi 76.9 \times 155$

纳入规格书

客户名称: 江苏吉泰科电气股份有限公司

物料编码:

受领印栏



注: 对此规格书确认后签名或签章, 然后返传一份与敝公司



Screw Terminal Al-capacitors 铝电解电容器

FE20600332M5C590 600V 3300 μ F 76.9 X 155 85 $^{\circ}$ C 2000h

Feature: 标准系列Standard Series
 符合ROHS要求ROHS compatible
 激光焊接连接端laser welding for electrical connetion
 小体积 Compact Size

**Aluminum Electrolytic Capacitors Specification
Capacitors with screw terminals**

螺钉铝电解电容器规格书

Series/Type: FE20
Ordering code: FE20600332M5C590
Date: July 16, 2013
Version: 1

拟定created: 洪海燕 审核checked : 王燕 批准 approval:



1. 适用范围 Adapt Range

本产品规格书适用于深圳市凯琦佳科技有限公司电解电容器产品系列:

FE20

The product specification is adapted to series Aluminum

FE20

Electrolytic Capacitors of Catchy and Excellent Technical Co., Ltd

2. 部品编号 Part Number System

| | | | | | | | |
|-------------|------------|--------------|-------------|----------|----------|---------------|-------------------|
| FE20 | 600 | 332 | M | 5 | C | 5 | 90 |
| ↓ | ↓ | ↓ | ↓ | ↓ | ↓ | ↓ | ↓ |
| 系列 | 标称电压 | 额定容量 | 容量组别 | M5 | 直径 | 端子 | 高度及其它要求 |
| Series | Rated V | Rated C (μF) | C Tolerance | Screw | D code | Terminal Code | length and others |
| | 600V | 3300 | | | 76.9 | | 155 |

3. 电气特性 Electrical characteristics (表1)

| 额定电压 Rated WV (V. DC) | 浪涌电压 Surge (V. DC) | 额定容量 Rated C (μF) | 容量偏差 C Tol. (%) | 损耗角正切 TGD (MAX) | ESR典型值 Typical ESR (mΩ) | 漏电流 IL (mA, MAX, 5min) | 最大纹波电流 Max ripple current (A) | 其它 others |
|---|--------------------------|-------------------------|-----------------------|--------------------|----------------------------|---------------------------------|-------------------------------------|-----------|
| 600 | 660 | 3300 | -20~+20 | 0.20 | 30 | 5 | 13.3 | |
| at 120Hz 20°C | | | | | | | 85°C 120Hz | |
| 气候类别 Environmental Category : 40/085/56 | | | | | | | | |

4. 性能特性 Specification

| No. | 项目 Item | 特性 Characteristics |
|-----|--|--|
| 1 | 外观检查 Visual examination, marking (Non-Destructive) | 外观: 无任何异常 Appearance: no remarkable abnormality |
| 2 | 外形尺寸 Dimensions (Non-Destructive) | 见外形图 See to dimensions |
| 3 | 漏电流 Leakage current (Non-Destructive) | 见表1 See to table 1 |
| 4 | 容量 Capacitance (Non-Destructive) | 见表1 See to table 1 |
| 5 | 损耗角正切 Tangent of the loss angle (Non-Destructive) | 见表1 See to table 1 |
| 6 | 端子强度 Robustness of terminations | 扭距Torque: 3.0N.m(Max) 拉力Tensile: 20N |



| | | | | | |
|----|-------------------|---|-------|------------------|-----|
| 7 | 振动 Vibration | 频率范围Frequency range: 10—55Hz 振幅: 0.75mm Total Amplitude: 0.75mm 条件: X.Y.Z 方向各2小时 Direction and duration of vibration: 3 orthogonal directions mutually each for 2 hours Total 6 hours 静电容量测试时无接触不良, 断线及短路, 端子无机械损伤 Capacitance: During the test, measured value to be stabilized (when measured several times within 30 min before completion of test)Appearance: No remarkable abnormality 静电容量变化: 初始值的-15~+15%以内 Capacitance change: Within -15~+15% of the initial value | | | |
| 8 | 稳态湿热 Dump heat | 温度: 40±2℃ 湿度: 90-95%Rh 时间: 56天 Test Temperature :40±2℃ Relative Hwmidity:90-95%Rh Test time: 56天 试验后常温放置1-2小时 To expose in the atmospheric condition for 1 to 2 hours after completion of test 漏电流: 不超过规定值 Leakage current: Not more than the specified value 静电容量变化: 初始值的-15~+15%以内 Capacitance change: Within -15 ~+15%of the initial value 损耗角正切: 不超过规定值 Dissipation Factor: Not more than the specified value 绝缘电阻 (使用金属箔法): 大于100MΩ Insulation Resistance (Using metal foil): ≥100MΩ | | | |
| 9 | 耐久性 Endurance | 时间 (Time) | 2000h | 温度 (temperature) | 85℃ |
| | | 电压: 额定电压 (叠加规定纹波电流) 试验后常温放置16h测定 Applied Voltage:maximum value of DC voltage overlapped by an allowable ripple current. The capacitors shall then be removed from the test chamber and stabilized at room temperature for 16 hrs. after。 漏电流: 不超过规定值 Leakage Current:Not more than the specified value 电容量变化: 初始值的-15~+15%以内 Capacitance change:within-15~+15% of the initial value 损耗角正切: 不超过规定值的1.75倍 Dissipation Factor:Not more than 175% of the specified value | | | |
| 10 | 浪涌 Surge | 印加电压 (VDC) | 660 | 温度 (temperature) | 85℃ |
| | | 周期: 6±0.5min 30±5sec充电 A period:6±0.5min(charging for 30±5sec) 充电电阻: 1000Ω 回数: 1000 times Series protective resistance The number of times 漏电流: 不超过规定值 Leakage Current:Not more than the specified value 电容量变化: 初始值的15%以内 Capacitance change:within 15% of the initial value 损耗角正切: 不超过规定值的1.75倍 Dissipation Factor:Not more than 175% of the specified value | | | |



| | | |
|----|---|---|
| 11 | 压力释放 Pressure relief | <p>电容器上印加10A 逆向直流电，防爆阀正常动作，无金属片飞散，起火，爆炸。</p> <p>The capacitor is shall be connected in inverse polarity, and applied DC current at 10A constant, The pressure relief device shall open in such a way as to avoid any danger of fire or explosion of capacitor elements</p> |
| 12 | 高温贮存 Storage at upper category temperature | <p>温度 (temperature) 85°C</p> <p>时间(Time): 500h 电压处理: 常温下电容器串联保护电阻(1K), 加额定电压30分钟, 印加后放电, 常温放置16h Condition: Following this period the capacitors shall be removed from the test chamber and be allowed to stabilize at room temperature. Next they shall be connected to a series limiting resistor (1K), with DC. Rated Voltage applied for 30 min. after which the capacitors shall be discharged.</p> <p>漏电流: 不超过规定值 Leakage Current: Not more than the specified value 电容量变化: 初始值的15%以内 Capacitance change: within 15% of the initial value 损耗角正切: 不超过规定值的1.75倍 Dissipation Factor: Not more than 175% of the specified value</p> |
| 13 | 绝缘耐压 insulation withstanding voltage | <p>2500VAC施加于短路的端子和固定卡箍之间, 1分钟不破坏 A voltage of 2500VAC is applied for one minute between the terminals shorted each other and the mounting clamp on insulating sleeve covering the case, there shall not be damaged</p> |

5. 标识 Marking

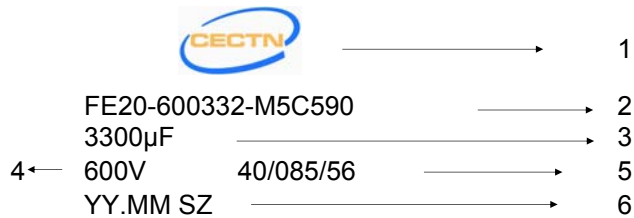

| No. | 项目Item | No. | 项目Item |
|-----|-------------------------|-----|-----------------------|
| 1 | 商标Brand | 5 | 气候类别 Climate category |
| 2 | 产品系列及料号 Products number | 6 | 日期及产地 Date and place |
| 3 | 静电容量Capacitance | | |
| 4 | 额定电压 Rated voltage | | |

6. 外型图 Dimensions

6-1 外形结构尺寸

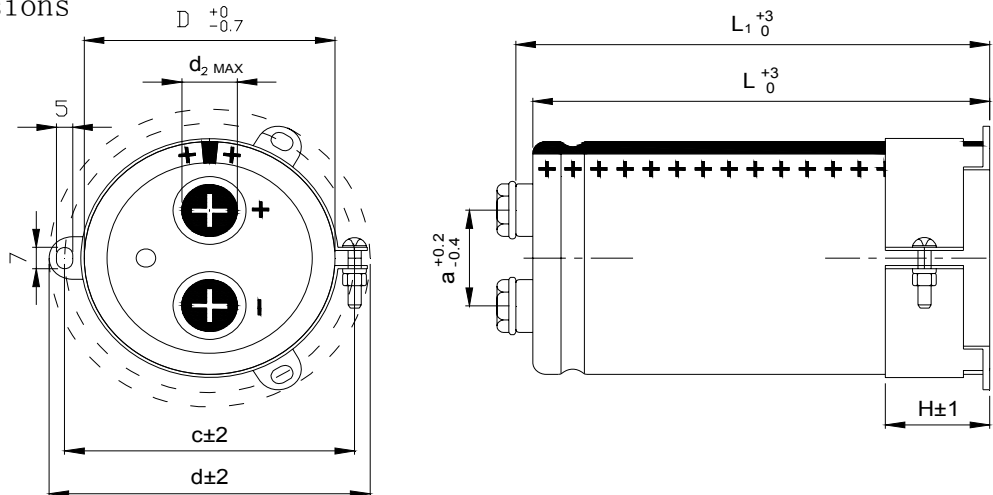

| | | | | |
|---------|--------------------------|---------|------------------------|-----------|
| D: 76.9 | d _{2MAX} : 17.7 | L: 155 | L ₁ : 160.8 | 螺丝: M5X12 |
| c: 88.9 | d: 98.4 | a: 31.7 | H: 30 | 套管层数: 2 |

7. 构造图(Frame drawing)

7-1 构造图(Frame drawing)

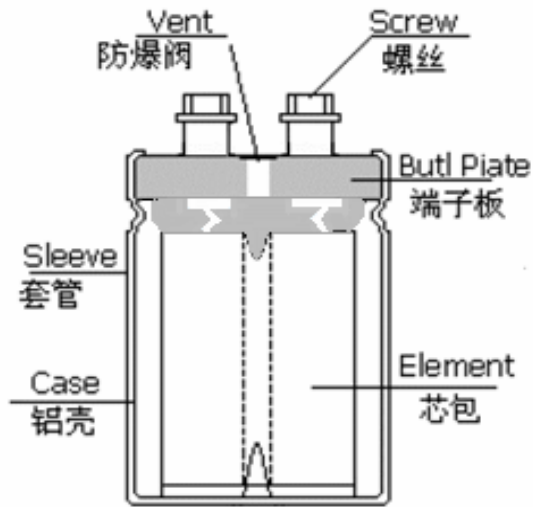

7-2 工艺芯包分解图 (Element drawing)

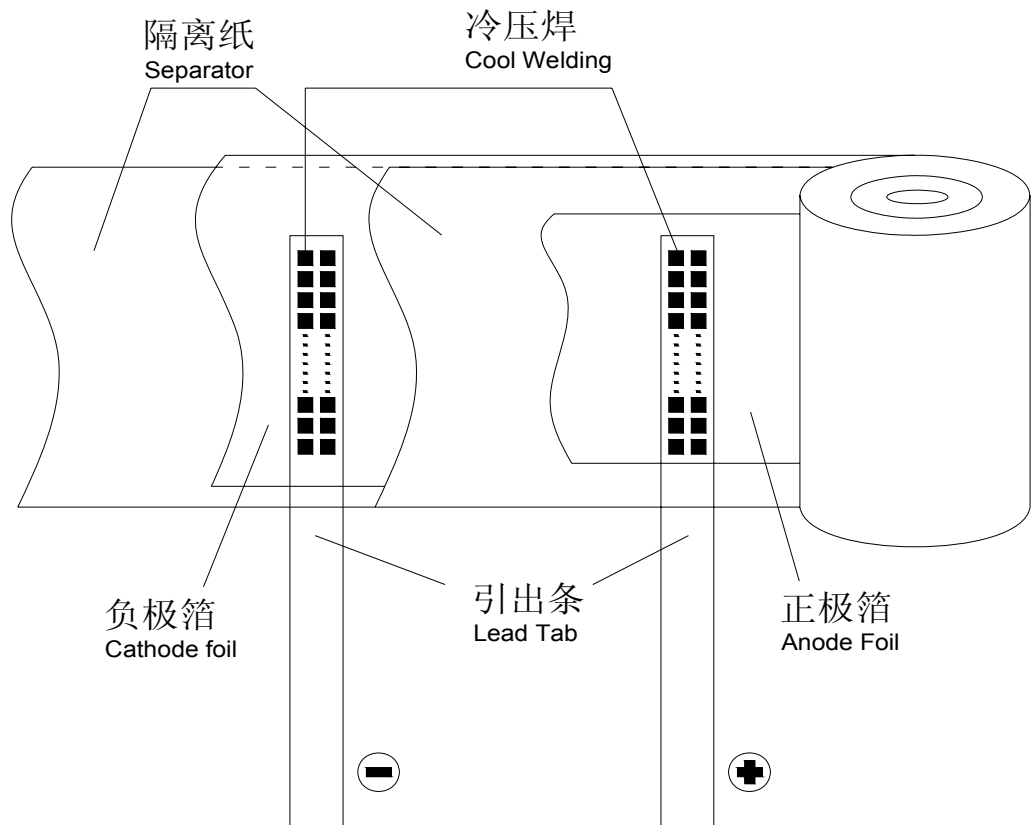



8. 纹波电流系数 Multiplier for ripple current

8-1 频率系数 Frequency Coefficient

| | | | | | |
|------------------|-------|-----|-----|-----|------|
| 频率 (Hz) Freq. | 50/60 | 120 | 300 | 1K | ≥10K |
| 系数 Coe. | 0.7 | 1.0 | 1.2 | 1.3 | 1.4 |

8-2 温度系数 Temperature Coefficient

| | | | | |
|----------------|------|-----|------|------|
| 温度(°C) Tem. | +40 | +60 | +70 | +85 |
| 系数 Coe. | 2.70 | 2 | 1.65 | 1.00 |

9. 包装 Packaging

9-1 包装数量 Packaging Quantity

| | | |
|----------------|-----------|-------|
| 电容器尺寸 | Φ76.9X155 | 12PCS |
| Capacitor case | Φ76.9X155 | 12PCS |

9-2 包装箱材质 Material of Packaging Box

瓦楞纸

Corrugated Cardboard

9-3 包装箱尺寸 Dimensions of Packaging Box

尺寸 Dimensions: 395X295X199

10. 生产日期的表示方法 Production date code

YY.MM.SZ

例 EX: 11 09 SZ

2011年9月份 深圳

Production date: produced in 09, 2011 Shenzhen